



REPUBLIC OF TRINIDAD AND TOBAGO

## PASSPORT REQUIREMENTS

### Lost, Stolen, Damaged/Destroyed Passports

#### GENERAL INFORMATION

**Purpose:** This application kit is for persons who wish to replace a Trinidad and Tobago passport that has been lost, stolen, damaged/ destroyed.

#### APPLYING TO REPLACE A LOST, STOLEN, DAMAGED/DESTROYED TRINIDAD AND TOBAGO PASSPORT

##### **How do I replace a lost, stolen, damaged/destroyed passport?**

*If your passport is lost or stolen you must report the matter to the police and provide the report or report number.*

*In case of destruction by fire, submit a report from the fire authorities.*

Complete a passport application form and include the fee, a copy of the police/fire report, as well as other documents as listed below.

**An affidavit indicating the circumstances as to how passport was lost, stolen, damaged/destroyed must also be sworn to.**

Persons 16 years of age or older must complete Adult Passport Application "Form A". Passport Application "Form B" must be completed for children between the ages of 0 and 15 years of age.

### Where can I obtain the passport application form?

Passport application forms **are not** available **online**. If you would like to receive an application form for a passport, please send a self addressed return envelope with appropriate postage to:

The High Commission Trinidad and Tobago  
7, Casablanca Street, Off Niarobi Street Off  
Aminu Kano Crescent, Wuse II, Abuja

### What documents should I submit?

The following documents must accompany your application for the replacement of a lost, stolen, damaged/destroyed Trinidad and Tobago passport. If any of the required documents are missing the application may be returned to you.

#### **You must include:**

- 1) A copy of the police report that was filed with this application.  
(The address and number of the police station at which the lost passport was reported, as well as the name and number of the officer who took the information.)
- 2) In case of damage by fire, a copy of the fire report, provided by the fire marshal.
- 3) A completed passport application form (Adult: Form "A", Child: Form "B")

*All passport applications must be completed by hand on an original form. We do not accept completed applications which are photocopied or which have been faxed to us. There is no facility for completing the form by e-mail.*

- 4) **Sworn declaration (affidavit) made before a Notary Public or Commissioner of Oaths** to include the name, number, place and date of issue of the lost, stolen or damaged passport. This notarial service can also be provided by the High Commission for a fee see **fees page**.  
**(payable by money order)**

The affidavit must detail the following:

- i) whether the passport was loaned or given to someone;
  - ii) that you hold no other valid passport and;
  - iii) an undertaking to submit the lost passport, if recovered, to the High Commission for the Republic of Trinidad and Tobago Office.
- 5) **The original of all documents**, along with a photocopy of each document. (The originals will be returned. Documents in languages other than English MUST be submitted with an Official Translation.)
- 6) Nigerian citizenship certificate(**not card**) or your Trinidad and Tobago Restoration Certificate, if applicable.

**Four (4)** recent identical photographs. One (1) of the photographs to be certified by the recommender on the application.

*Please note that the T&T passport photo carries a larger face size than the Nigerian Passport.*

Instructions for photographer: Actual photo size should be **53mm x 43mm**. From the hairline to the chin must measure between **25mm and 35mm**. Photos must be taken face forward without head covering (no side view). Colour or black and white photographs are accepted.

**No substitutions will be accepted. It is your responsibility to ensure that the photographer complies with our requirements.**

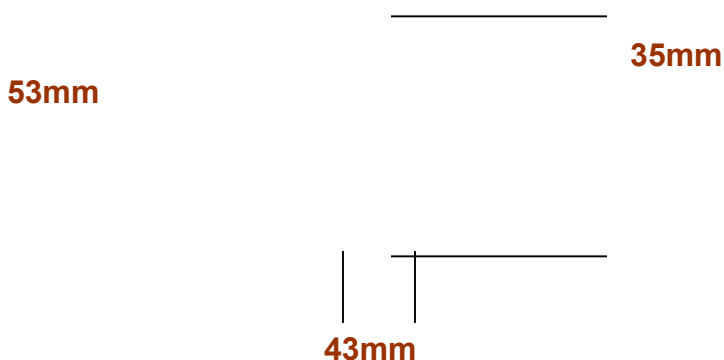

- 7) **Birth Certificate** (with affidavit, if necessary) together with any other documents that will assist in your identification, e.g. cancelled passport, baptismal certificate, driver's license, Nigerian Immigration Landed Status document, etc. (**Originals and one copy**)

8) **Declaration of recommender**

(The recommender who countersigns your application must have known you personally for **at least three (3) years** and known you well enough to be confident that the statements you have made in the application are true). Your recommender must be a Trinidad and Tobago or Nigeria citizen in one of the following professional groups/positions of authority:

- Minister of religion, registered under law to perform marriages.
- Managing Director, Director and Manager of Banks and Companies, Credit Union or Trust company (Endorsement of Official Stamps necessary)
- Professionals (University Graduates)
- Member of Parliament, Mayor, Borough or County Councillor
- Notary Public/ Justice of the Peace/ Commissioner of Affidavits
- Senior Public Servant (Federal/ Provincial)
- Police Officer, (municipal, provincial, RCMP; Corporal and above rank)
- Fire (sub-officer and above rank)
- Prison Cadet Officer and above rank
- Member of the Defence Force (Corporal/ Leading Seaman and above rank)
- Graduate Teacher-School Principal, Vice-Principal, Lecturer
- Senior Administrator in a Community College (includes CEGEPs)

9) **Marriage data**

If your marital status has changed since obtaining your last passport you must produce the original of your marriage certificate obtained from the Registrar General's Office and/or divorce decree.

If married more than once, final divorce document or death certificate of former husband/wife. Married women using their maiden name must submit a marriage certificate obtained from the Registrar General's Office.

- 10) **Form "C<sup>2</sup>"** must be used in conjunction with Form A if you are submitting your application through the mail or if your spouse brings in your application. **Form "C<sup>2</sup>"** will be dispatched to you with the relevant passport application form.

11) **Change of Name (other than marriage):**

Documents required:

- (a) Deed Poll or Court Order
- (b) OR Adoption Certificate OR Change of Name Certificate (as applicable)

## **PASSPORT APPLICATION REQUIREMENTS FOR CHILDREN**

Parent or legal guardian must complete application form "B".

### **You must include:**

- 1) Completed Application Form "B"

(All passport applications must be completed by hand on an original form. We do not accept completed applications which are photocopied or which have been faxed to us. There is no facility for completing the form by e-mail.)

- 2) **The original of all documents**, along with a photocopy of each document.

(The originals will be returned. Documents in languages other than English MUST be submitted with an Official Translation.)

- 3) Three **(3)** recent identical photographs of the child, which meet the same photograph for adults as state above. One of the photographs must be certified on the back by the recommender.

- 4) Documentary evidence of the child's Trinidad and Tobago citizenship, i.e. birth certificate or certificate of Trinidad and Tobago citizenship.

- 5) **If the child is a citizen by descent you should also provide:**

- i. The child's Trinidad and Tobago citizenship certificate, if applicable;
- ii. The child's birth certificate, showing the names of the parents;
- iii. Proof of the parent's Trinidad and Tobago citizenship, i.e.: their current Trinidad and Tobago passport/s, birth certificate/s, and marriage certificate (which indicates Trinidad and Tobago citizenship at the time of the child's birth).

- 6) **Separated or divorced parent:**

The parent to whom custody of the child/children has been awarded in applying for passports must produce **evidence of the Court Order** and any other documentary evidence as may be required.

- 7) **If the child is a citizen by naturalization you should also provide**

- a) Certificate of naturalization, and Birth certificate

8) **If the child is a citizen by adoption you should also provide:**

a) Certificate of adoption, and Birth Certificate

9) **Declaration of recommender:**

The recommender who countersigns the application must have known you personally for **at least three(3) years** and known you and the child well enough to be confident that the statements you have made in the application are true. The instructions for the recommender are the same as for adults as stated above.

10) **Form "C<sup>3</sup>"** must be used in conjunction with Form "B" if you are submitting the application through the mail. **Form "C<sup>3</sup>"** will be dispatched to you with the relevant passport application form.

**Fee:** Please see **fees page**

**Postage:** Please note that passports are returned **ONLY** by registered mail. Should you wish to receive your passport by mail, please submit along with returned envelope of any courier services.

**Where Do I Submit My Application?**

Submit your application in person or by mail to the address found below:

The High Commission for the Republic of Trinidad and Tobago  
7, Casablanca Street, Off Nairobi, Aminu Kano,  
Crescent Wuse II, Abuja.

### **Do I need to attend an interview?**

Please be advised that you will be required to have an interview with the Consular officer at the High Commission, Abuja when the application is submitted for the replacement of a valid passport.

### **Please Note:**

There could be a delay in issuance of a replacement passport depending on the accuracy of the details supplied, documents submitted, and the approval of the authorities in Trinidad and Tobago. You are therefore encouraged to apply well in advance of your travel date.

You can assist in the shortening of the processing time by ensuring the accuracy of the information provided, concerning the date and place of the loss and by submitting all documents necessary.

### **For how long is the passport valid?**

Adult passports are normally issued with a 10-year validity while children under the age of 16 are issued with passports that are valid for five (5) years only.

Once the passport has reached the maximum validity of 10 or 5 years respectively, an application should be made for a new one.